



**AVERY
DENNISON**

Fastener
Solutions

All System 1000 Fasteners Marketing Specifications

These categories appear in the next 6 pages:

Nylon System 1000 Fasteners

Polypropylene System 1000 Fasteners

Ecotach rPET System 1000 Fasteners (rPET 95%PCW)

Ecotach rPA System 1000 Fasteners (rPA 30%PCW)

March 19, 2024

AVERY DENNISON MARKETING SPECIFICATION

© 2019 AVERY DENNISON CORPORATION. ALL RIGHTS RESERVED

HISTORY

REV.	DATE	DESCRIPTION
	11.14.19	REMOVE DIM, EDIT DIM & REV

ITEM NUMBER	REV	MATERIAL	COLOR	FILAMENT LENGTH, DIM A (IN/[MM])	FILAMENT LENGTH, DIM B (IN/[MM])	OVERALL LENGTH, DIM C (IN/[MM])	MINIMUM APPLIED STRENGTH (LBS/[KGF])
10332-0	C	POLYPROPYLENE	NATURAL	0.40 - 0.50 / [10 - 13]	NA	0.75 - 0.85 / [19 - 22]	4.5 / [2.0]
08284-0	N	POLYPROPYLENE	NATURAL	NA	0.8 - 1.1 / [20 - 28]	1.0 - 1.3 / [25 - 33]	4.5 / [2.0]
10315-0	N	POLYPROPYLENE	RED	NA	0.8 - 1.1 / [20 - 28]	1.0 - 1.3 / [25 - 33]	4.5 / [2.0]
10316-0	N	POLYPROPYLENE	BLUE	NA	0.8 - 1.1 / [20 - 28]	1.0 - 1.3 / [25 - 33]	4.5 / [2.0]
10317-0	N	POLYPROPYLENE	GREEN	NA	0.8 - 1.1 / [20 - 28]	1.0 - 1.3 / [25 - 33]	4.5 / [2.0]
10318-0	N	POLYPROPYLENE	YELLOW	NA	0.8 - 1.1 / [20 - 28]	1.0 - 1.3 / [25 - 33]	4.5 / [2.0]
10311-0	A	POLYPROPYLENE	NATURAL	NA	1.2 - 1.4 / [31-36]	1.4 - 1.6 / [36 - 41]	4.5 / [2.0]
10334-0	C	POLYPROPYLENE	NATURAL	NA	1.45 - 1.65 / [38 - 43]	1.65 - 1.85 / [43 - 46]	4.5 / [2.0]
08285-0	H	POLYPROPYLENE	NATURAL	NA	2.0 - 2.2 / [51 - 56]	2.2 - 2.4 / [56 - 61]	4.5 / [2.0]
10699-0	C	NYLON	NATURAL	0.40 - 0.50 / [10 - 13]	NA	0.75 - 0.85 / [19 - 22]	7.0 / [3.2]
10698-0	C	NYLON	NATURAL	NA	0.75 - 0.95 / [19 - 24]	0.95 - 1.15 / [24 - 29]	7.0 / [3.2]
10418-0	E	NYLON	NATURAL	NA	0.9 - 1.1 / [23 - 28]	1.1 - 1.4 / [28 - 36]	7.0 / [3.2]
10415-0	J	NYLON	NATURAL	NA	1.5 - 1.8 / [38 - 46]	1.7 - 2.0 / [43 - 51]	7.0 / [3.2]
11005-0	D	NYLON	NATURAL	NA	2.0 - 2.2 / [51 - 56]	2.2 - 2.4 / [56 - 61]	7.0 / [3.2]

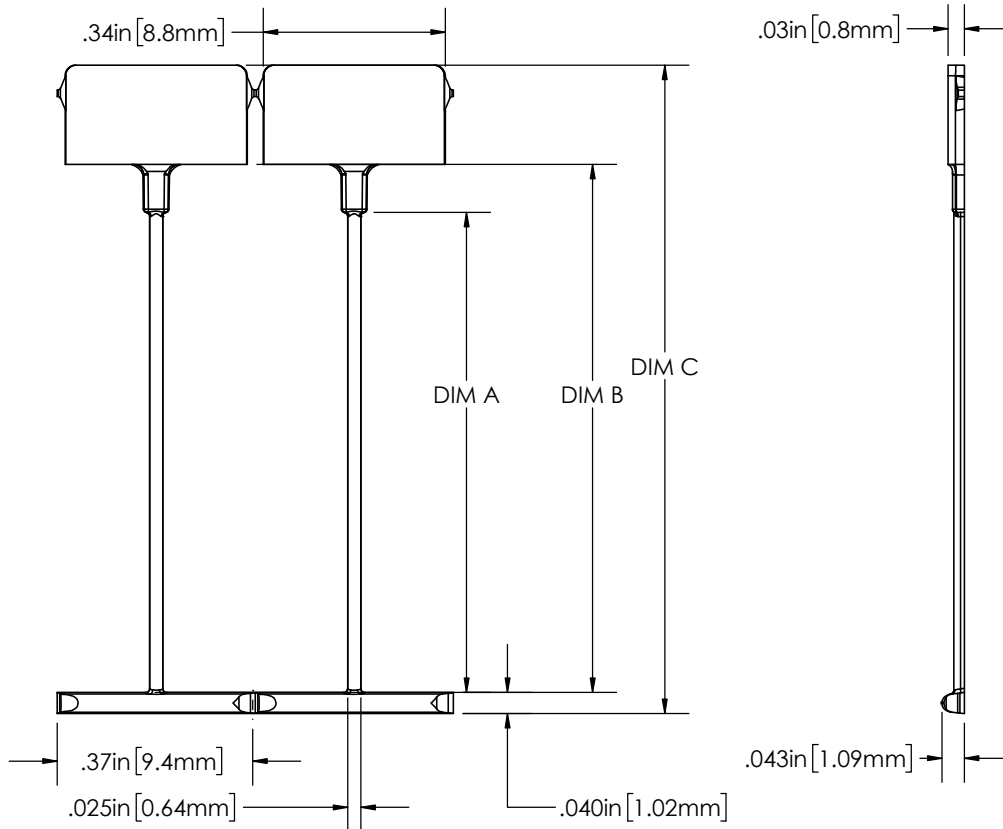

NOT TO SCALE

WEIGHT, PP:	.035 g	ROLL QUANTITY:	1,000	APPLICATION TOOL SYSTEM 1000™ HAND TOOL (10000-4) INDUSTRIAL SYSTEM 1000 TOOL (SPU5P, SPU5M). CONTACT SALES SPECIALIST FOR OTHER OPTIONS
WEIGHT, NYLON:	.049 g	CARTON QUANTITY:	5,000	
		CASE QUANTITY:	50,000	

APPROVALS:	ENG. APPR.	<i>Bert Uschold</i>	11.14.19
	Q.A. APPR.	<i>Rick Estano</i>	11.14.19



FASTENER DIVISION
FITCHBURG, MA 01420 U.S.A.
TEL. 1-800-225-5913
FAX. 978-353-8157

SPECIFIED TOLERANCES ARE:		MATERIAL	DESCRIPTION
.XX ± .03 INCHES	.X ± .7 mm	SEE TABLE	SYSTEM 1000™ PADDLE
.XXX ± .010 INCHES	.XX ± .25 mm	COLOR	STOCK NO.
ANGULAR: ± 2°		SEE TABLE	SEE TABLE
			REV. SEE TABLE

EVERY DENNISON MARKETING SPECIFICATION

© 2021 EVERY DENNISON CORPORATION. ALL RIGHTS RESERVED

HISTORY

REV.	DATE	DESCRIPTION
A	12.6.21	CREATE SPECIFICATION

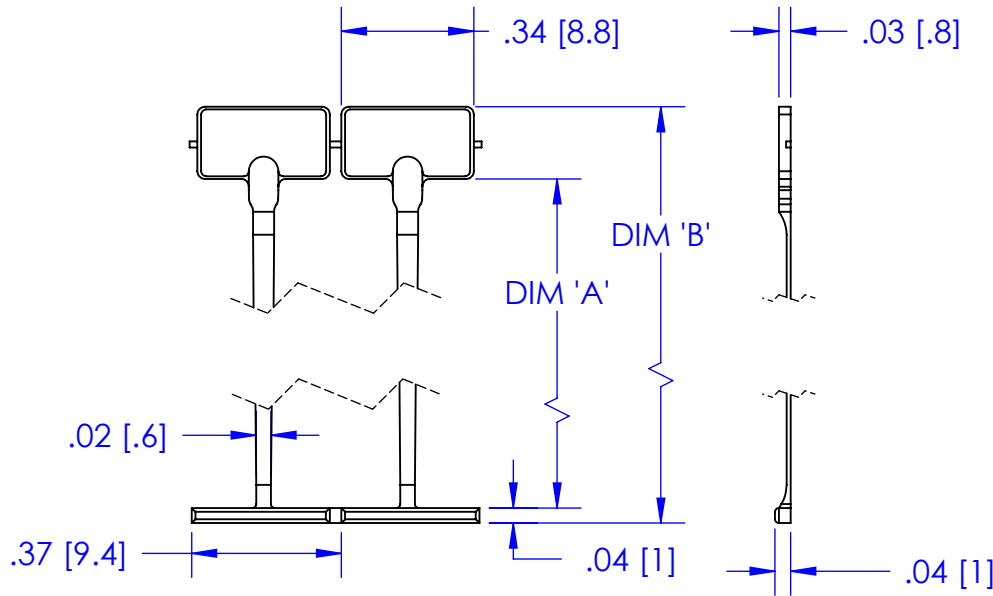

STOCK NUMBER	REV	COLOR	DIM 'A'	DIM 'B'	WEIGHT
17180-0	A	GRAY	.37/.47 [9.4mm/12mm]	.60/.70 [15.2mm/17.8mm]	.05g ea
17181-0	A	GRAY	.52/.62 [13.2mm/15.7mm]	.75/.85 [19.1mm/21.6mm]	.05g ea
17182-0	A	GRAY	.77/.90 [19.5mm/22.9mm]	1.00/1.13 [25.4mm/28.7mm]	.05g ea
17183-0	A	GRAY	.97/1.07 [24.6mm/27.2mm]	1.20/1.30 [30.5mm/33mm]	.05g ea
17184-0	A	GRAY	1.22/1.32 [31mm/33.5mm]	1.45/1.55 [36.8mm/39.4mm]	.05g ea
17185-0	A	GRAY	1.42/1.62 [36.1mm/41.1mm]	1.65/1.85 [41.9mm/47mm]	.05g ea
17186-0	A	GRAY	1.67/1.77 [42.4mm/45mm]	1.90/2.00 [48.3mm/50.8mm]	.05g ea
17187-0	A	GRAY	2.04/2.11 [51.8mm/53.6mm]	2.23/2.30 [56.6mm/58.4mm]	.05g ea

MIN. APPLIED TENSILE	7 LBSF [3.2 KGF]
MATERIAL	70% Nylon; 30% rPA (RECYCLED NYLON)
WEIGHT	SEE TABLE
ROLL QUANTITY	1000
CARTON QUANTITY	5000
CASE QUANTITY	50 000
APPLICATION TOOL	SYSTEM 1000 HAND TOOL (10000-4); INDUSTRIAL SYSTEM 1000 TOOL (SPU5P AND SPU5M); CONTACT SALES SPECIALIST FOR OTHER OPTIONS

APPROVALS:	ENG. APPR. <i>Dave Schuttler 12.6.21</i>	 FASTENER DIVISION FITCHBURG, MA 01420 U.S.A. TEL. 1-800-225-5913 FAX. 978-353-8157
	Q.A. APPR. <i>Rick Estano 12.6.21</i>	
SPECIFIED TOLERANCES ARE: .XX ± .03 INCHES .X ± .7 mm .XXX ± .010 INCHES .XX ± .25 mm ANGULAR: ± 2°		DESCRIPTION Ecotach™ System 1000 rPA (RECYCLED NYLON)
MATERIAL SEE TABLE		STOCK NO. SEE TABLE
COLOR SEE TABLE		REV. A



Fastener
Solutions

Ecotach™ Recycled (rPET) Fasteners Marketing Specifications

For the following part numbers:

17015-0	Standard System 1000	2" (51mm)
17016-0	Standard System 1000	2" (51mm)
17017-0	Standard System 1000	2" (51mm)
17001-0	Standard System 1000	3" (78mm)
17002-0	Standard System 1000	3" (78mm)
17003-0	Standard System 1000	3" (78mm)
17004-0	Standard System 1000	3" (78mm)
17005-0	Standard System 1000	3" (78mm)
17006-0	Standard System 1000	3" (78mm)
17007-0	Standard System 1000	3" (78mm)
17008-0	Standard System 1000	3" (78mm)
17009-0	Standard System 1000	3" (78mm)
17010-0	Standard System 1000	3" (78mm)
17011-0	Standard System 1000	3" (78mm)
17012-0	Standard System 1000	3" (78mm)
17013-0	Standard System 1000	3" (78mm)
17041-0	Fine Fabric System 500	2" (51mm)
17042-0	Fine Fabric System 500	2" (51mm)
17043-0	Fine Fabric System 500	2" (51mm)

March 6, 2020

AVERY DENNISON MARKETING SPECIFICATION

© 2019 AVERY DENNISON CORPORATION. ALL RIGHTS RESERVED

HISTORY

REV.	DATE	DESCRIPTION
D	02.11.20	ADD 17015-0,-16-0 AND -17-0: TENSILE OF 4.0 WAS 5.6LBS

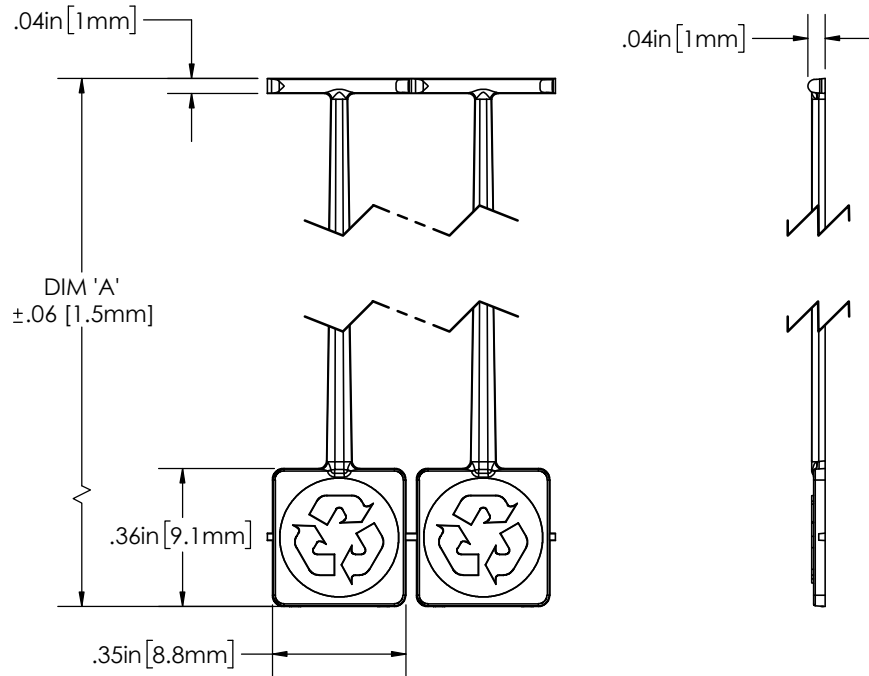

STOCK NUMBER	REV	COLOR	DIM 'A'
17001-0	D	WHITE	3.0 [76mm]
17002-0	D	YELLOW	3.0 [76mm]
17003-0	D	ORANGE	3.0 [76mm]
17-004-0	D	PINK	3.0 [76mm]
17005-0	D	RED	3.0 [76mm]
17006-0	D	LT GREEN	3.0 [76mm]
17007-0	D	GREEN	3.0 [76mm]
17008-0	D	LT BLUE	3.0 [76mm]
17009-0	D	DK BLUE	3.0 [76mm]
17010-0	D	BROWN	3.0 [76mm]
17011-0	D	GRAY	3.0 [76mm]
17012-0	D	BLACK	3.0 [76mm]
17013-0	D	NATURAL	3.0 [76mm]
17015-0	A	NATURAL	2.0 [51mm]
17016-0	A	BLACK	2.0 [51mm]
17017-0	A	WHITE	2.0 [51mm]

NOT TO SCALE

TENSILE STRENGTH: 4.0 lbf [1814 g] MINIMUM		APPROVALS: ENG. APPR. <i>Dave Schuttler 02.11.20</i> Q.A. APPR. <i>Rick Estano 02.11.20</i>	SPECIFIED TOLERANCES ARE: .XX ± .03 INCHES .X ± .7 mm .XXX ± .010 INCHES .XX ± .25 mm ANGULAR: ± 2°		MATERIAL >= 90%rPET <= 10% PE& COLOR CONC.	DESCRIPTION	
WEIGHT: .107 GRAMS/EACH						SYSTEM 1000, rPET	
TOOL: 10000-4 - HAND TOOL SPU5M / SPU5P - IND'L SYSTEM 1000 (CONTACT SALES SPECIALIST FOR ADDITIONAL OPTIONS)		MATERIAL >= 90%rPET <= 10% PE& COLOR CONC.		DESCRIPTION		SYSTEM 1000, rPET	
PACKAGING: 834/ROLL 5000/CTN, 50,000/CASE				MATERIAL >= 90%rPET <= 10% PE& COLOR CONC.		STOCK NO. SEE TABLE	



FASTENER DIVISION
FITCHBURG, MA 01420 U.S.A.
TEL. 1-800-225-5913
FAX. 978-353-8157

AVERY DENNISON MARKETING SPECIFICATION

© 2019 AVERY DENNISON CORPORATION. ALL RIGHTS RESERVED

Released Product

HISTORY

REV.	DATE	DESCRIPTION
A	02.28.20	RELEASE

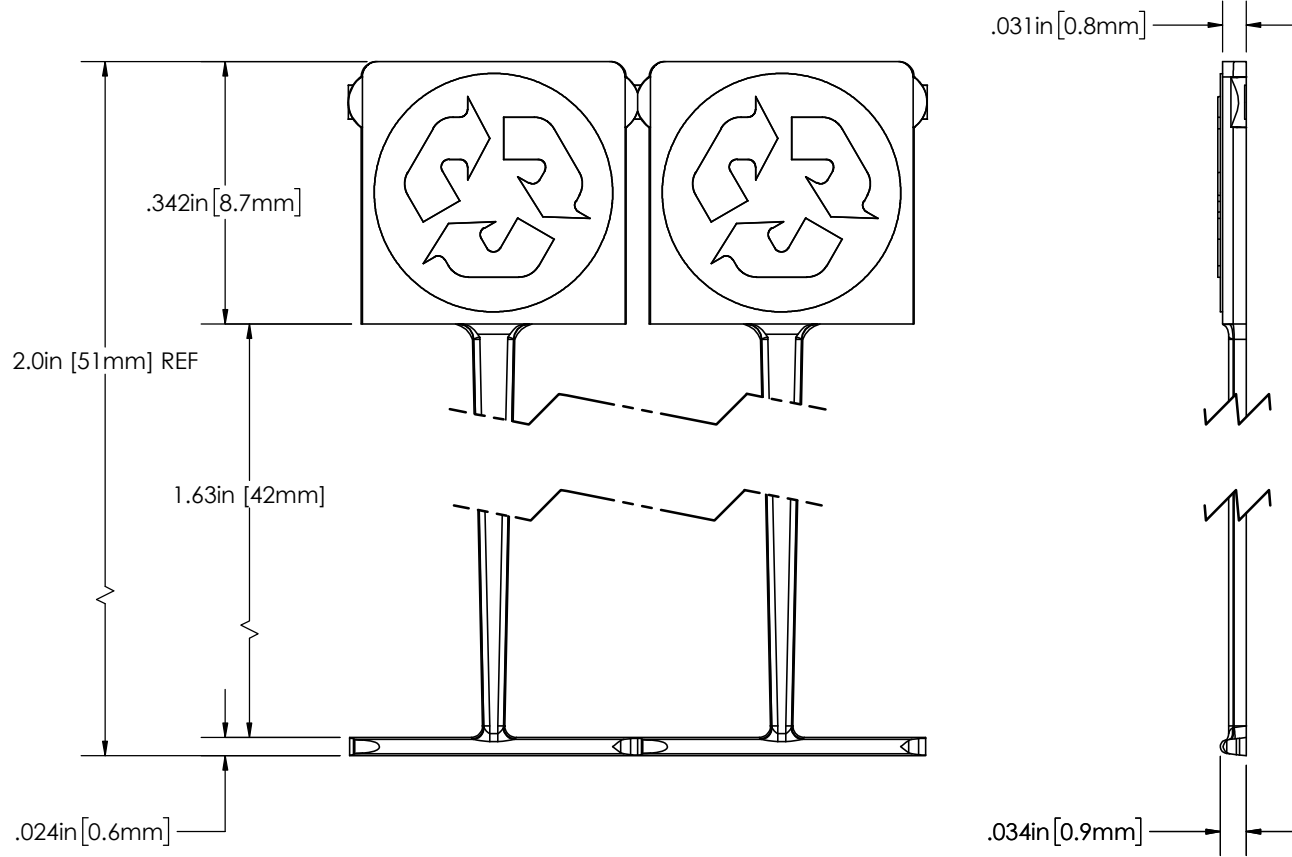

STOCK NUMBER	REV	COLOR
17041-0	A	NATURAL
17042-0	A	BLACK
17043-0	A	WHITE

NOT TO SCALE

TENSILE STRENGTH: 2.5 lbf [1134g MINIMUM]	APPROVALS: ENG. APPR. <i>Dave Schuttler 02.28.20</i> Q.A. APPR. <i>Rick Estano 02.28.20</i>	MATERIAL >/= 90% rPET </=10% PE & COLOR CONC COLOR SEE TABLE	DESCRIPTION SYSTEM 500 FF, rPET STOCK NO. SEE TABLE
WEIGHT: .09 GRAMS/EACH			
PACKAGED: 5000/CTN, 50,000/CASE	SPECIFIED TOLERANCES ARE: .XX ± .03 INCHES .X ± .7 mm .XXX ± .010 INCHES .XX ± .25 mm ANGULAR: ± 2°	FASTENER DIVISION FITCHBURG, MA 01420 U.S.A. TEL. 1-800-225-5913 FAX. 978-353-8157	REV AA
APPLICATION TOOL: 16010-0 - HAND TOOL (CONTACT SALES SPECIALIST FOR ADDITIONAL OPTIONS)			
ROLL QUANTITY: 500 FASTENERS			

5 4 3 2 1